

RV-8 C-GURV		
Wiring Diagram Tree		
Code	Dwg No. C-GURV- 0000	Rev 5
Drawn By M. Richardson	Date 27 Sept 2011	
Scale None	Page: 1 of 20	

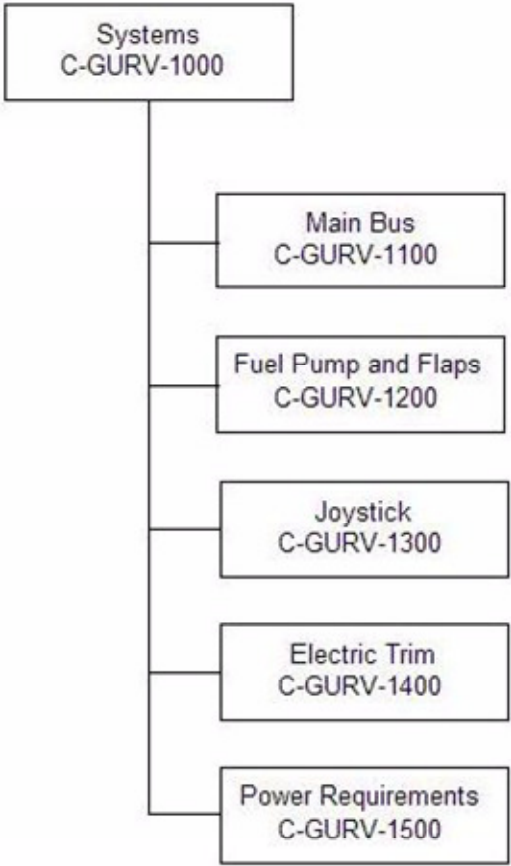

RV-8 C-GURV		
Systems		
Code	Dwg No. C-GURV- 1000	Rev 5
Drawn By M. Richardson	Date 27 Sept 2011	
Scale None	Page: 2 of 20	

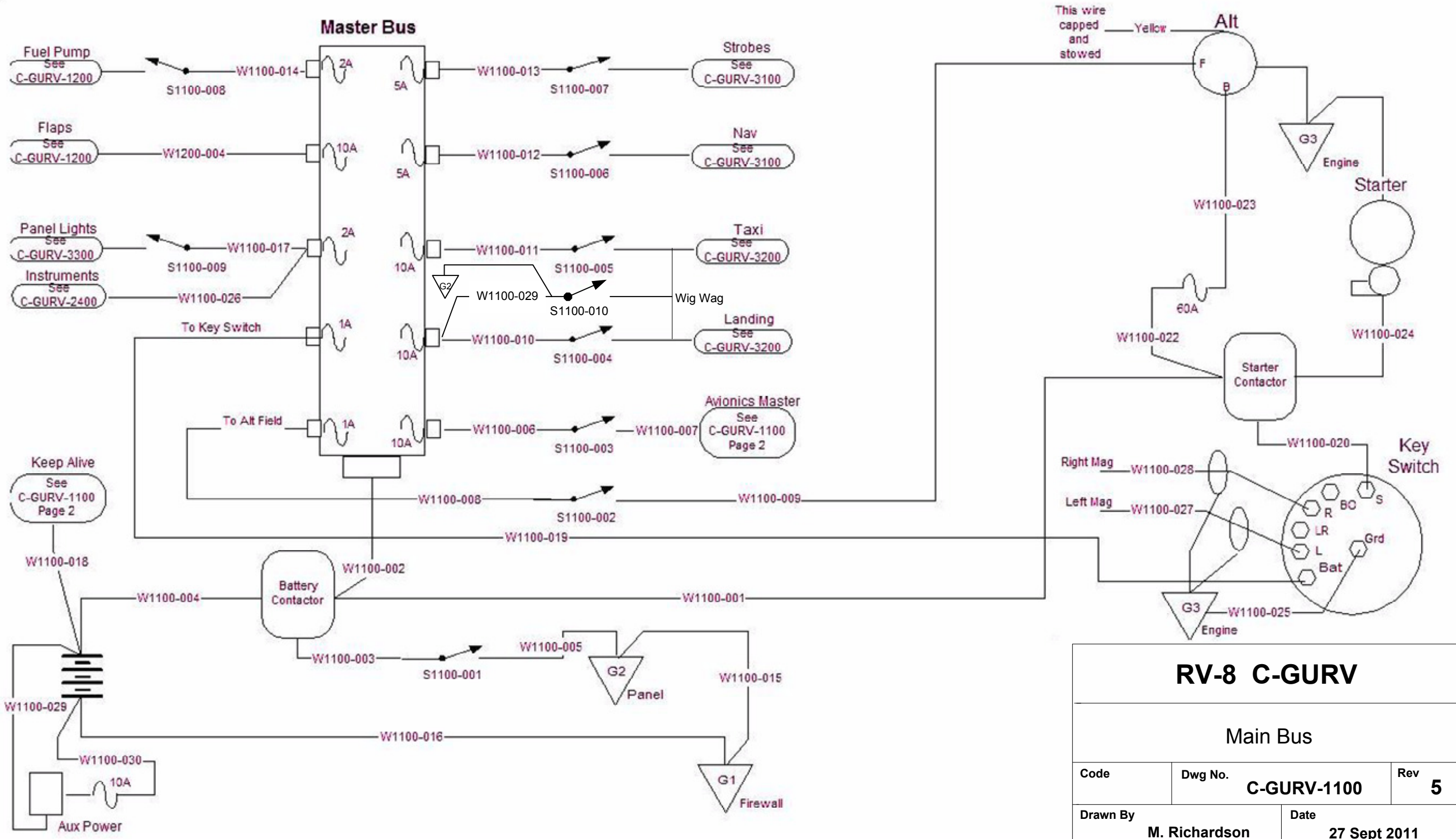

RV-8 C-GURV		
Main Bus		
Code	Dwg No.	Rev
	C-GURV-1100	5
Drawn By	Date	
M. Richardson	27 Sept 2011	
Scale	Page: 3 of 20	
None		

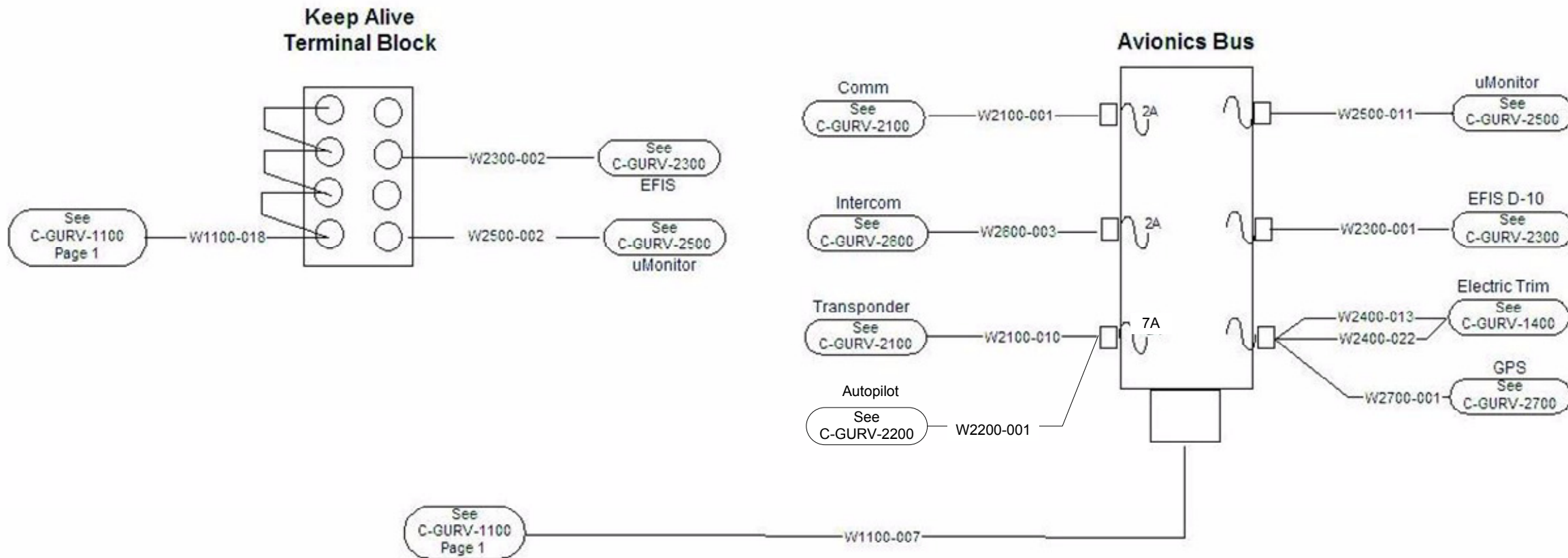

RV-8 C-GURV		
Main Bus		
Code	Dwg No. C-GURV- 1100	Rev 5
Drawn By	M. Richardson	Date 27 Sept 2011
Scale None	Page: 4 of 20	

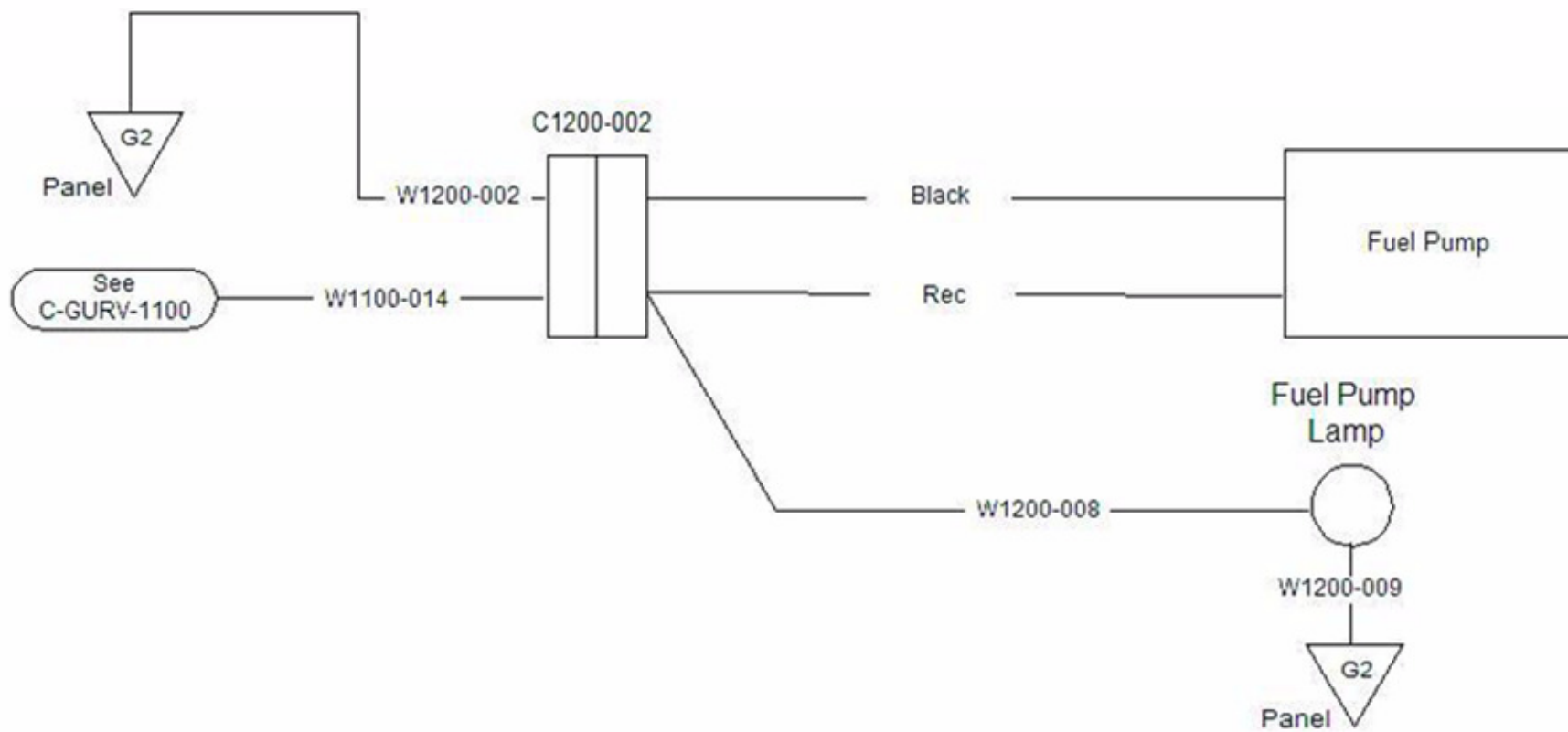
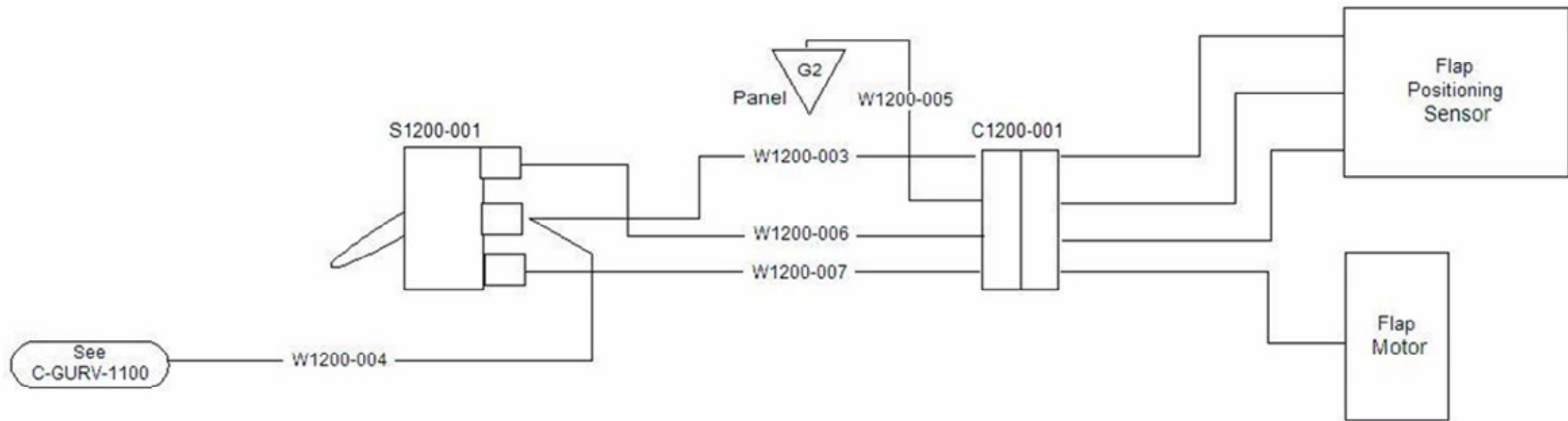

RV-8 C-GURV		
Fuel Pump		
Code	Dwg No. C-GURV- 1200	Rev 5
Drawn By	M. Richardson	Date 27 Sept 2011
Scale	None	Page: 5 of 20

Pilot Joystick

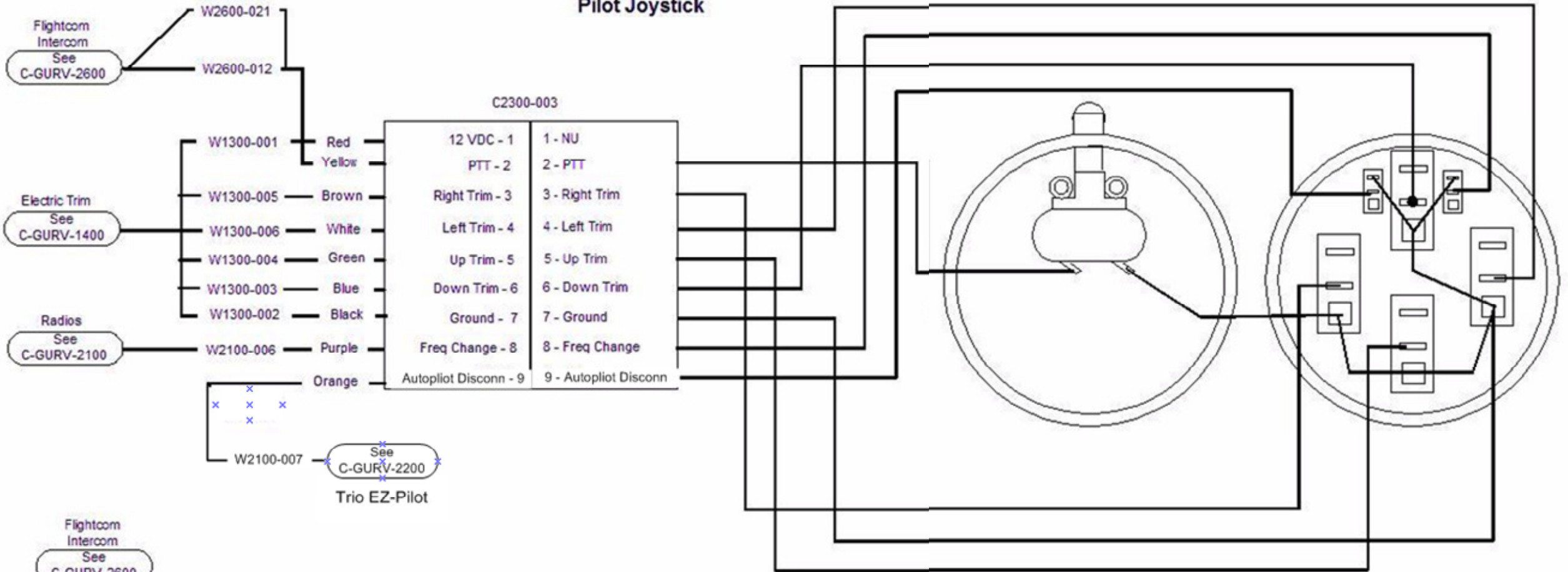

Co-Pilot Joystick

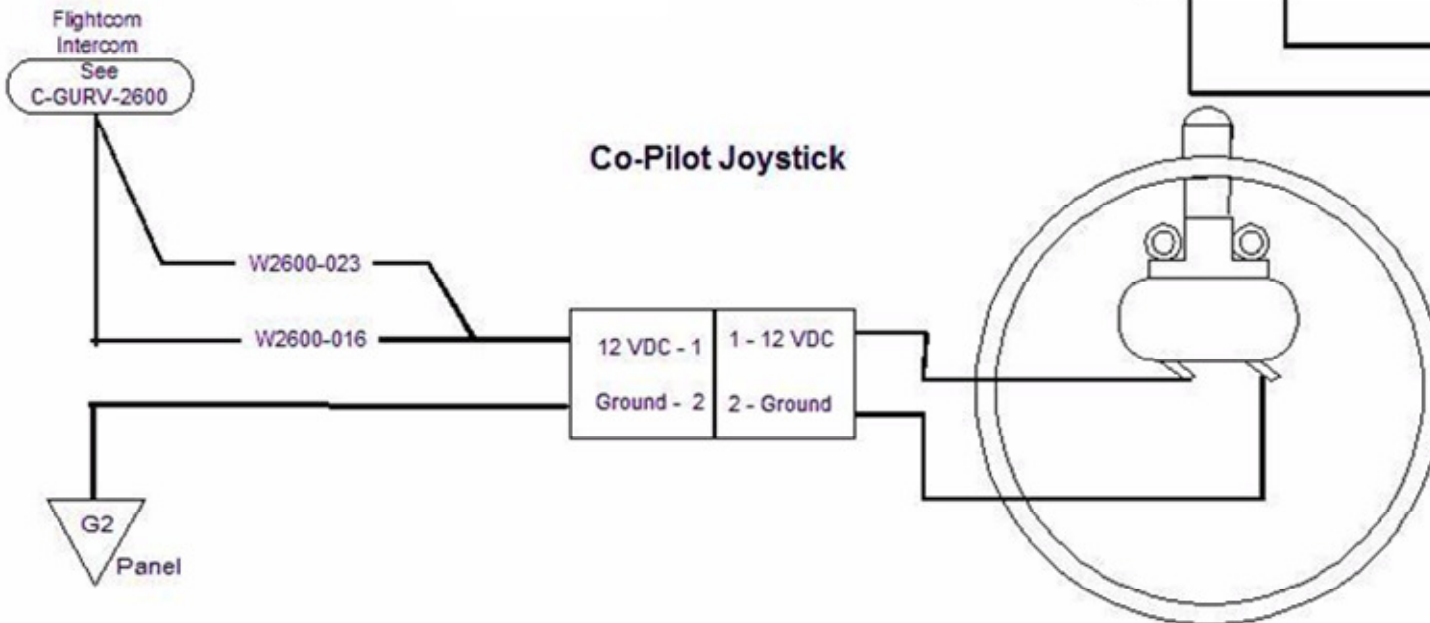

RV-8 C-GURV

Joystick

Code	Dwg No.	Rev
	C-GURV- 1300	5
Drawn By	Date	
M. Richardson	27 Sept 2011	
Scale	Page: 6 of 20	
None		

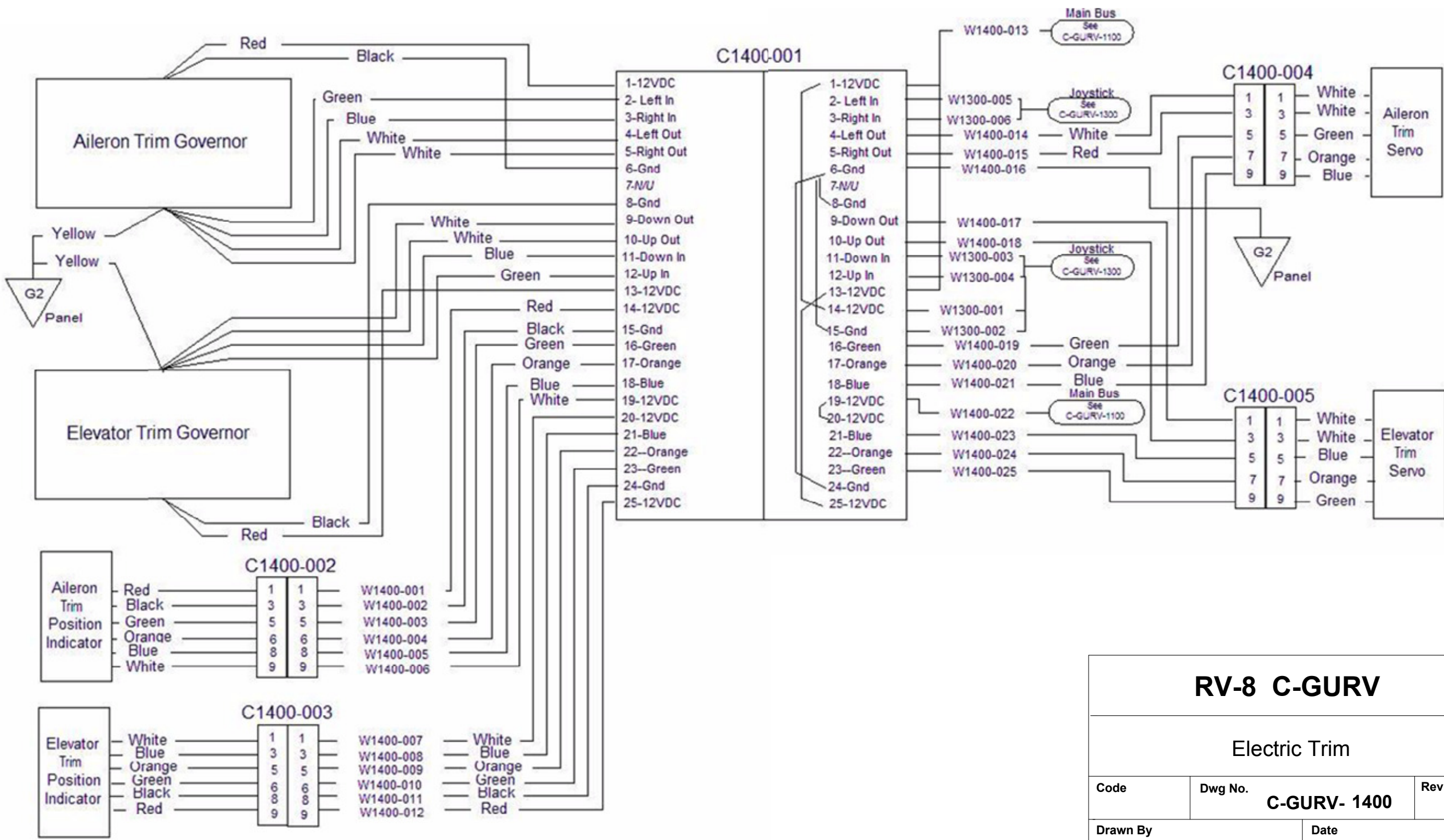

RV-8 C-GURV		
Electric Trim		
Code	Dwg No. C-GURV- 1400	Rev 5
Drawn By	Date	
M. Richardson	27 Sept 2011	
Scale	Page: 7 of 20	
None		

Power Requirements

27.86

Quantity	Description	Current	Total
1	MicroAir Comm	1.2	1.2
1	MicroAir Transponder	0.4	0.4
1	RMI uEncoder	0.4	0.4
1	RMI uMonitor	0.1	0.1
1	Dynon EFIS	1.2	1.2
6	Instruments	0.1	0.6
1	Intercom	0.16	0.16
1	Landing Light	4	4
1	Taxi Light	4	4
2	Stobe Lights	1.75	3.5
2	Position Lights	1.8	3.6
2	Nav Lights	1.9	3.8
1	Aileron Trim	0.15	0.15
1	Elevator Trim	0.15	0.15
1	Flaps	3	3
1	Fuel Pump	1	1
1	GPS	0.1	0.1
1	Panel Lights	0.5	0.5

RV-8 C-GURV		
Power Requirements		
Code	Dwg No. C-GURV- 1500	Rev 5
Drawn By M. Richardson	Date 27 Sept 2011	
Scale None	Page: 8 of 20	

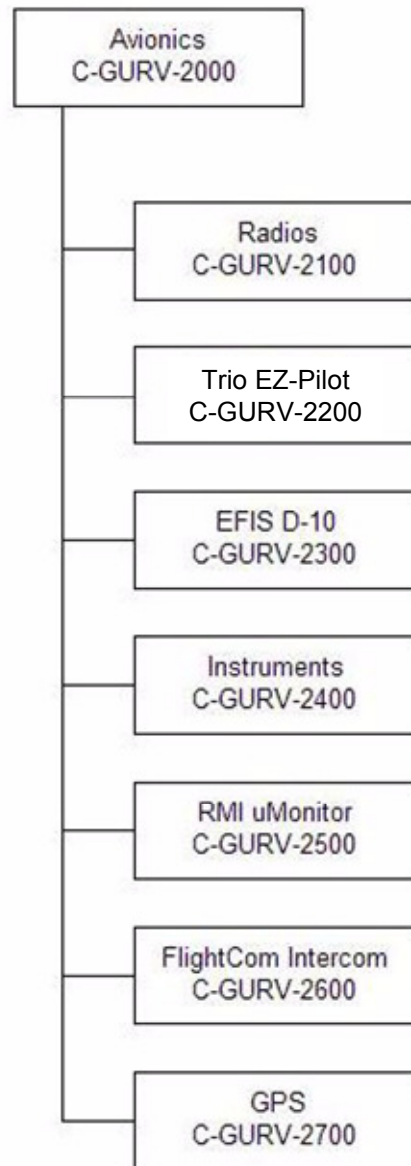

RV-8 C-GURV		
Avionics		
Code	Dwg No. C-GURV- 2000	Rev 5
Drawn By	M. Richardson	Date 27 Sept 2011
Scale	None	Page: 9 of 20

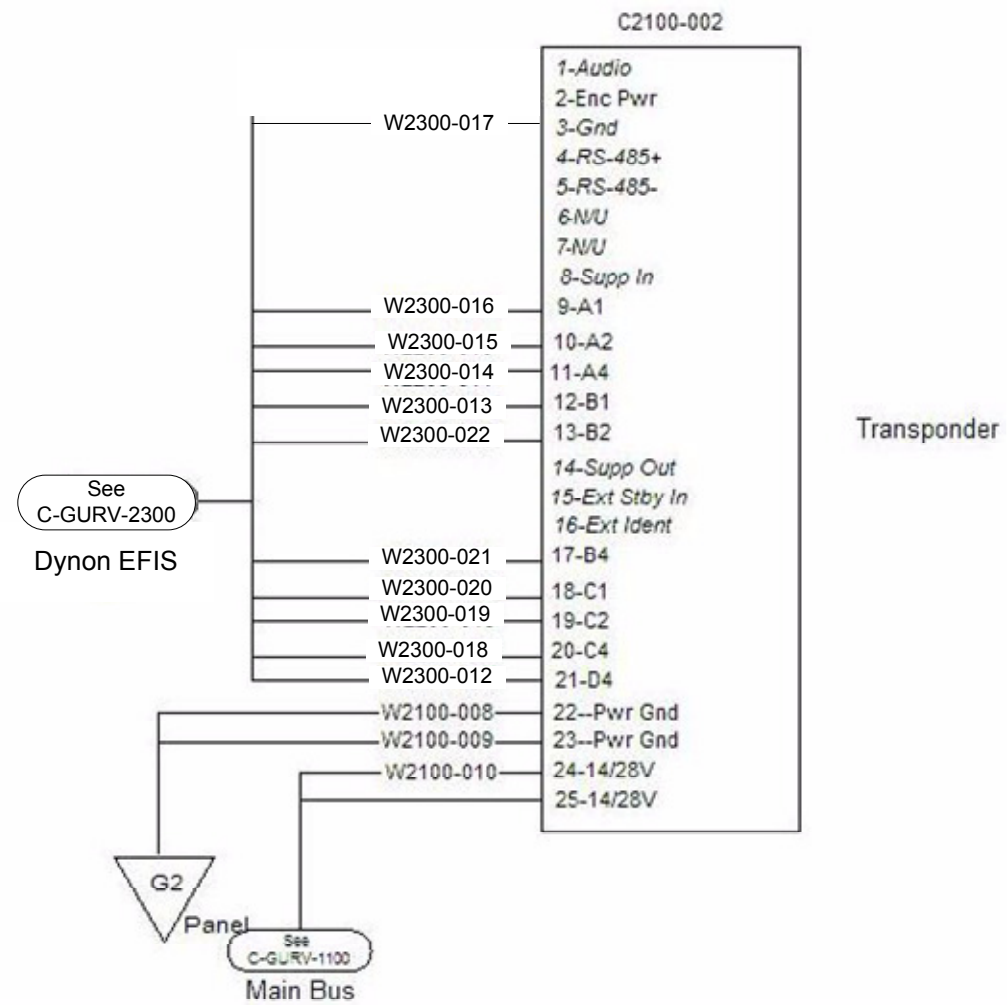
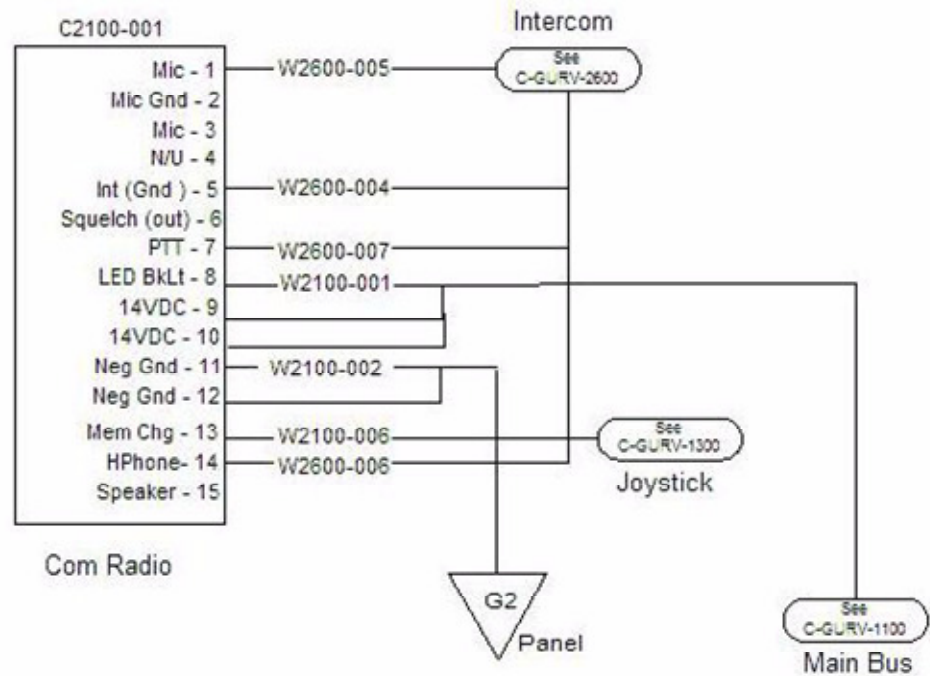

RV-8 C-GURV		
Radios		
Code	Dwg No. C-GURV- 2100	Rev 5
Drawn By	Date	
M. Richardson	27 Sept 2011	
Scale None	Page: 10 of 20	

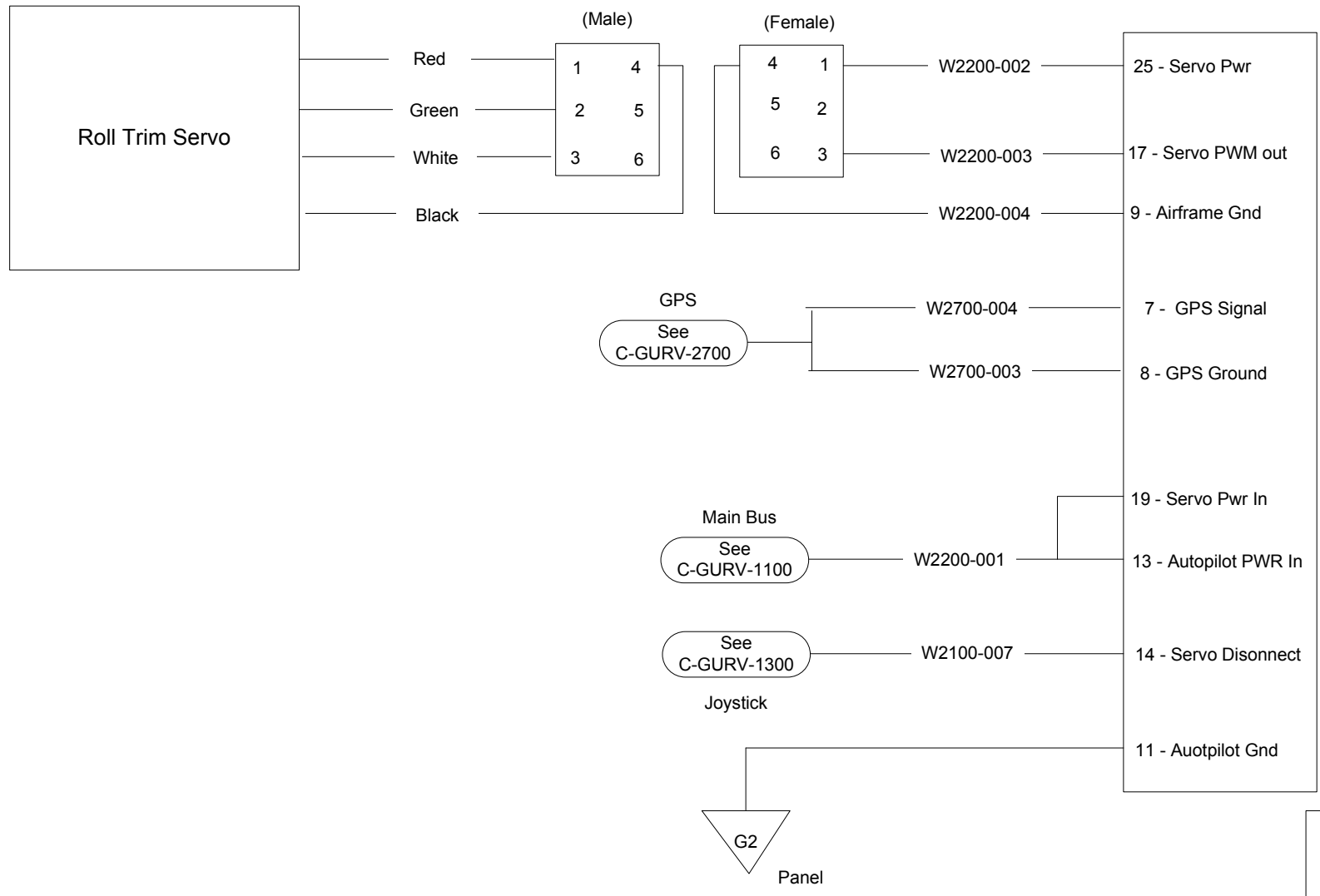

DB-25 On the EZ-Pilot Control Head

RV-8 C-GURV		
Trio EZ-Pilot		
Code	Dwg No. C-GURV- 2200	Rev 5
Drawn By M. Richardson	Date 27 Sept 2011	
Scale None	Page: 11 of 20	

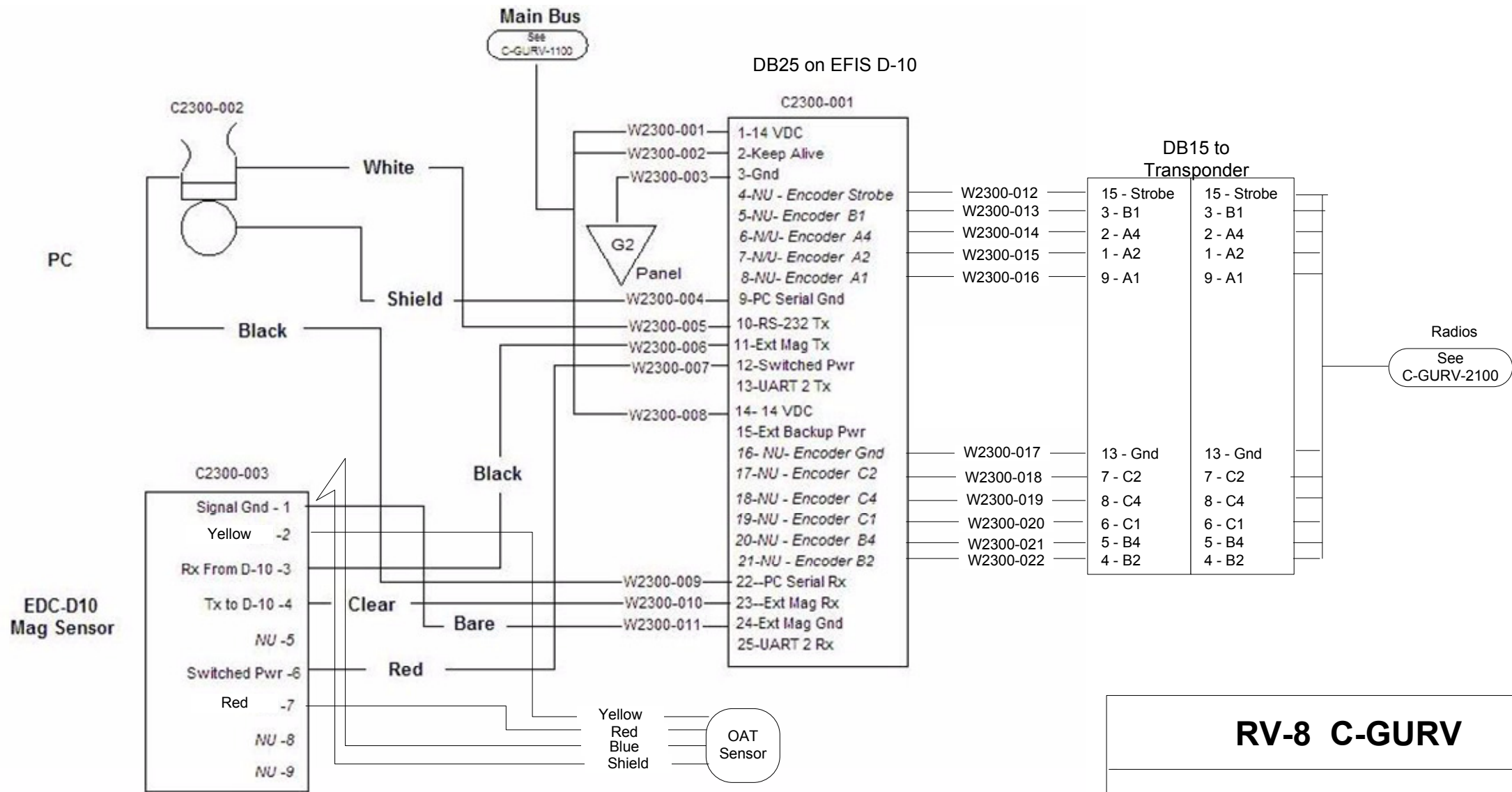

RV-8 C-GURV		
EFIS D-10		
Code	Dwg No. C-GURV- 2300	Rev 5
Drawn By M. Richardson	Date 27 Sept 2011	
Scale None	Page: 12 of 20	

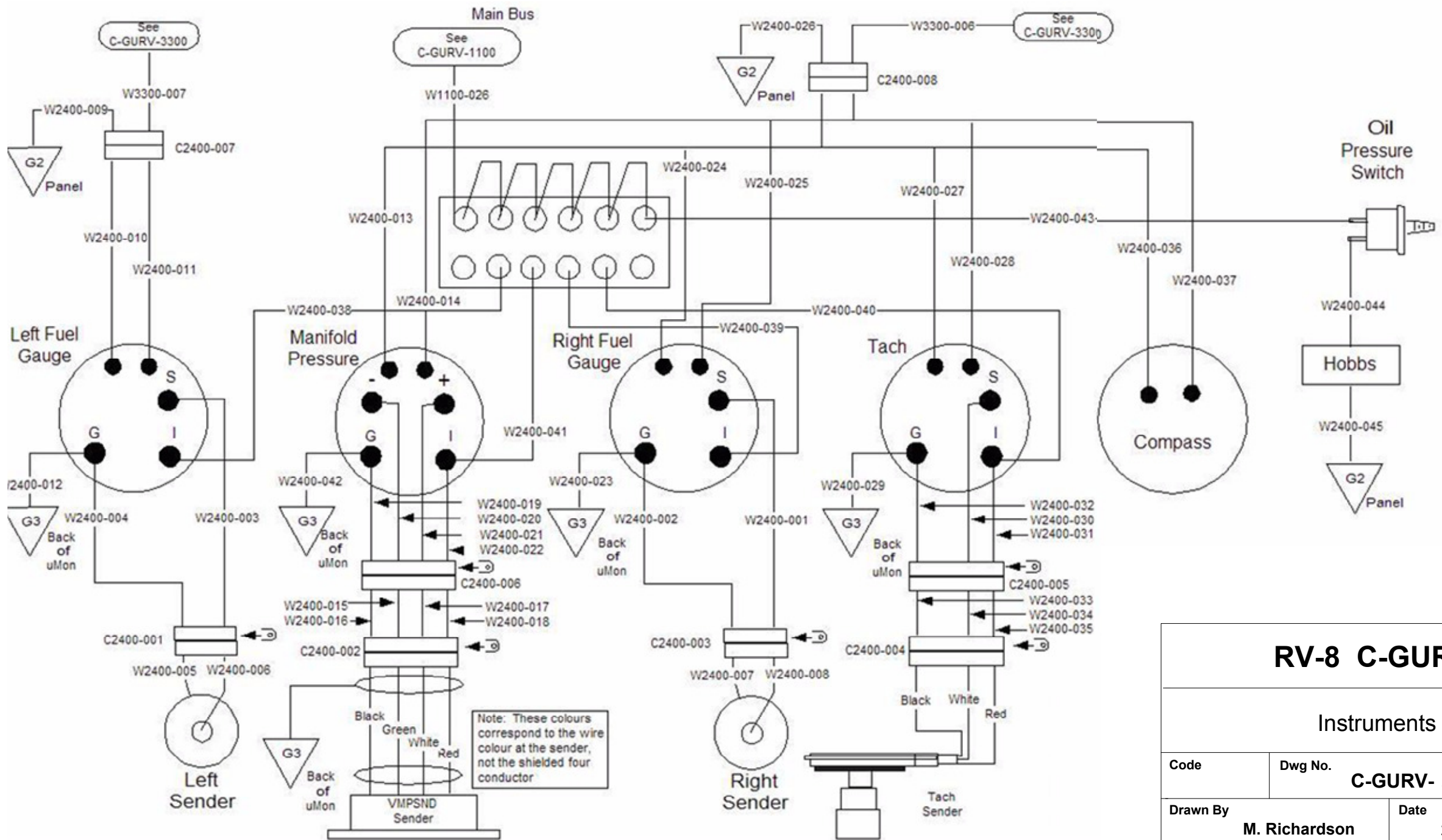

RV-8 C-GURV

Instruments

Code	Dwg No.	Rev
	C-GURV- 2400	5
Drawn By	Date	
M. Richardson	27 Sept 2011	
Scale	Page: 13 of 20	
None		

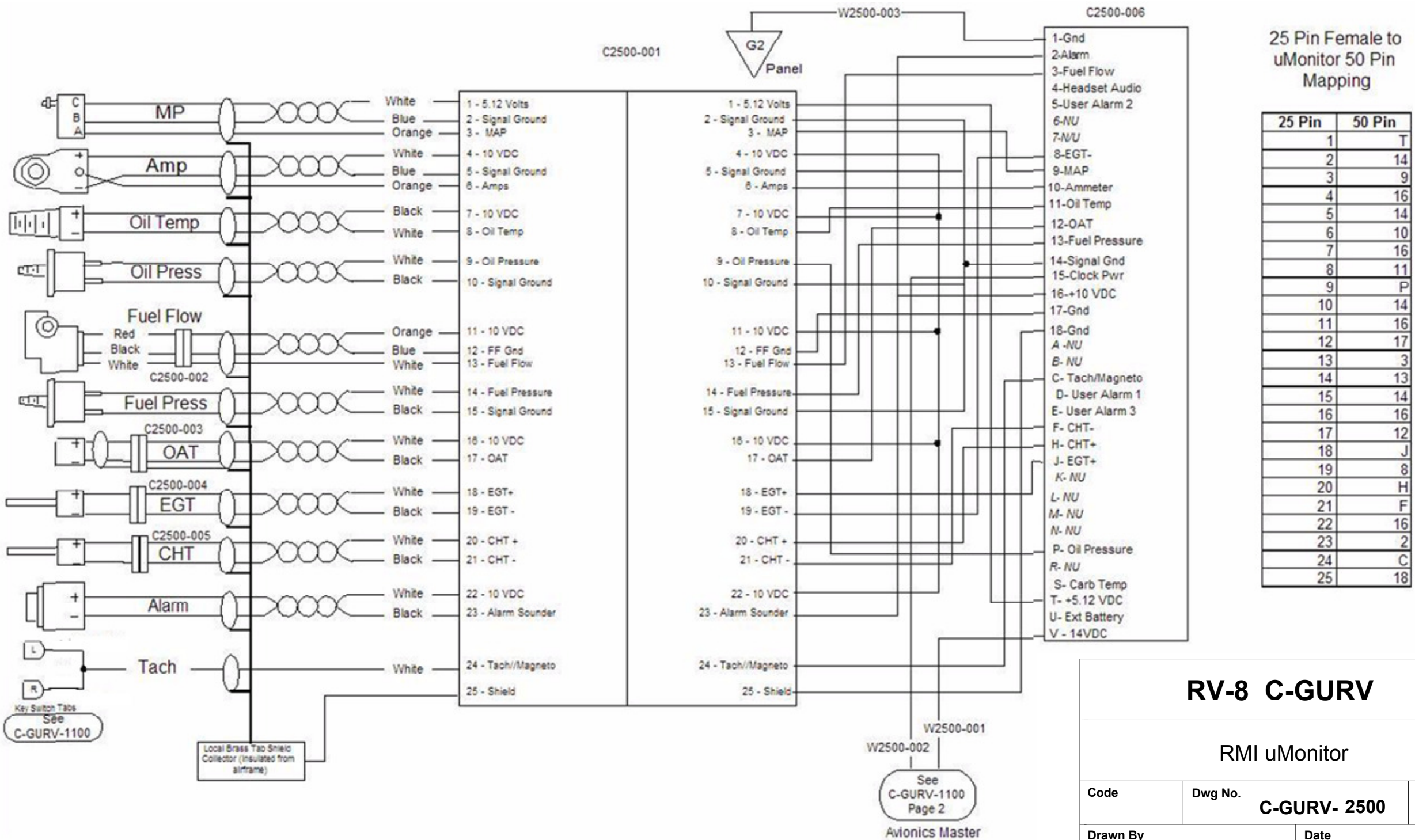

RV-8 C-GURV

RMI uMonitor

Code	Dwg No.	Rev
	C-GURV- 2500	5
Drawn By	Date	
M. Richardson	27 Sept 2011	
Scale	Page: 14 of 20	
None		

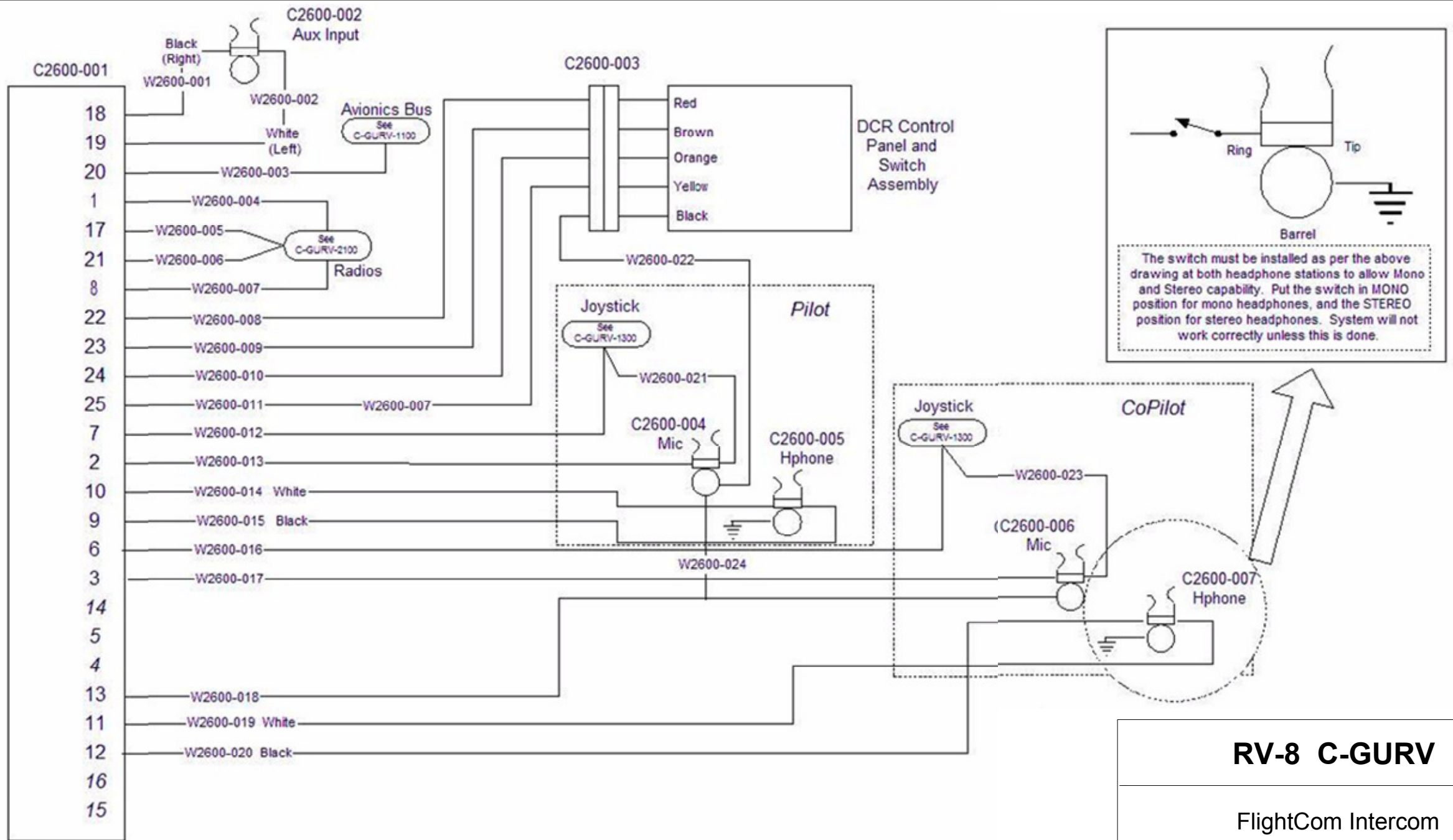

Intercom
25 Pin

RV-8 C-GURV		
FlightCom Intercom		
Code	Dwg No. C-GURV- 2600	Rev 5
Drawn By M. Richardson	Date 27 Sept 2011	
Scale None	Page: 15 of 20	

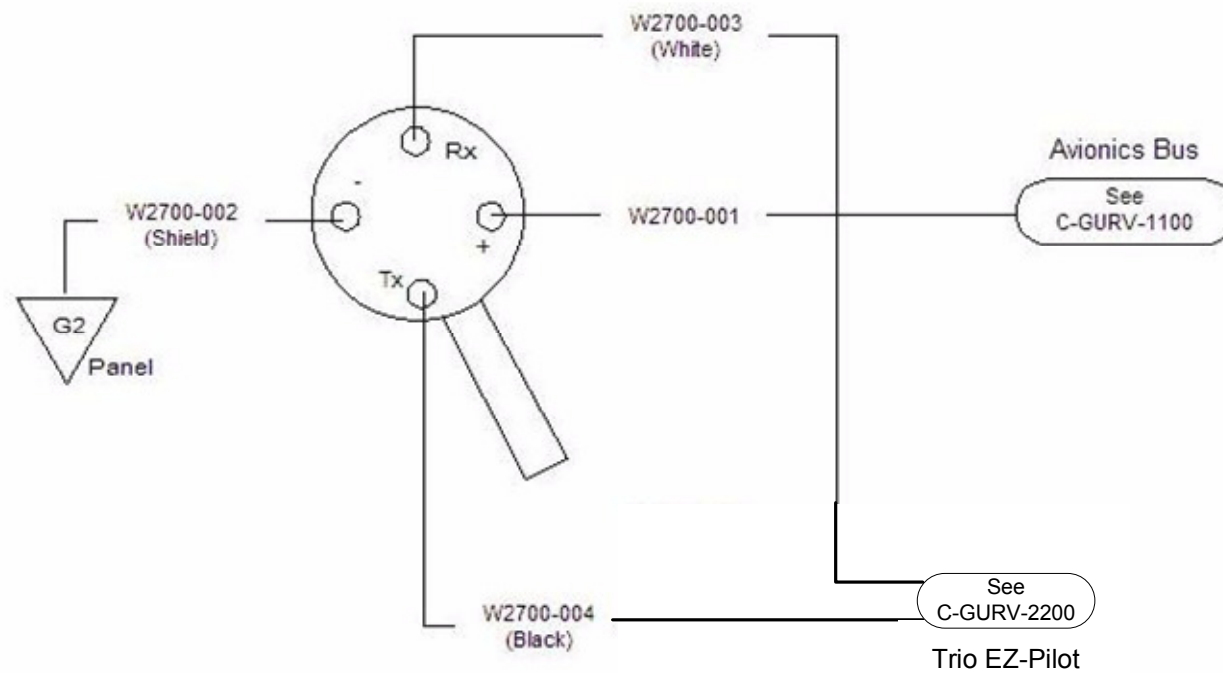

RV-8 C-GURV		
Garmin 196 GPS		
Code	Dwg No. C-GURV- 2700	Rev 5
Drawn By M. Richardson	Date 27 Sept 2011	
Scale None	Page: 16 of 20	

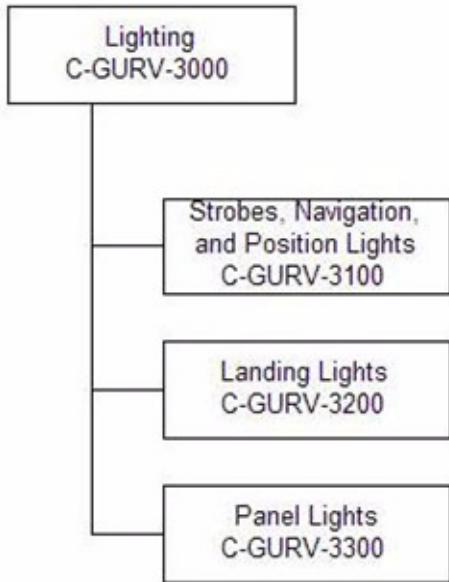

RV-8 C-GURV		
Lighting		
Code	Dwg No. C-GURV- 3000	Rev 5
Drawn By M. Richardson	Date 27 Sept 2011	
Scale None	Page: 17 of 20	

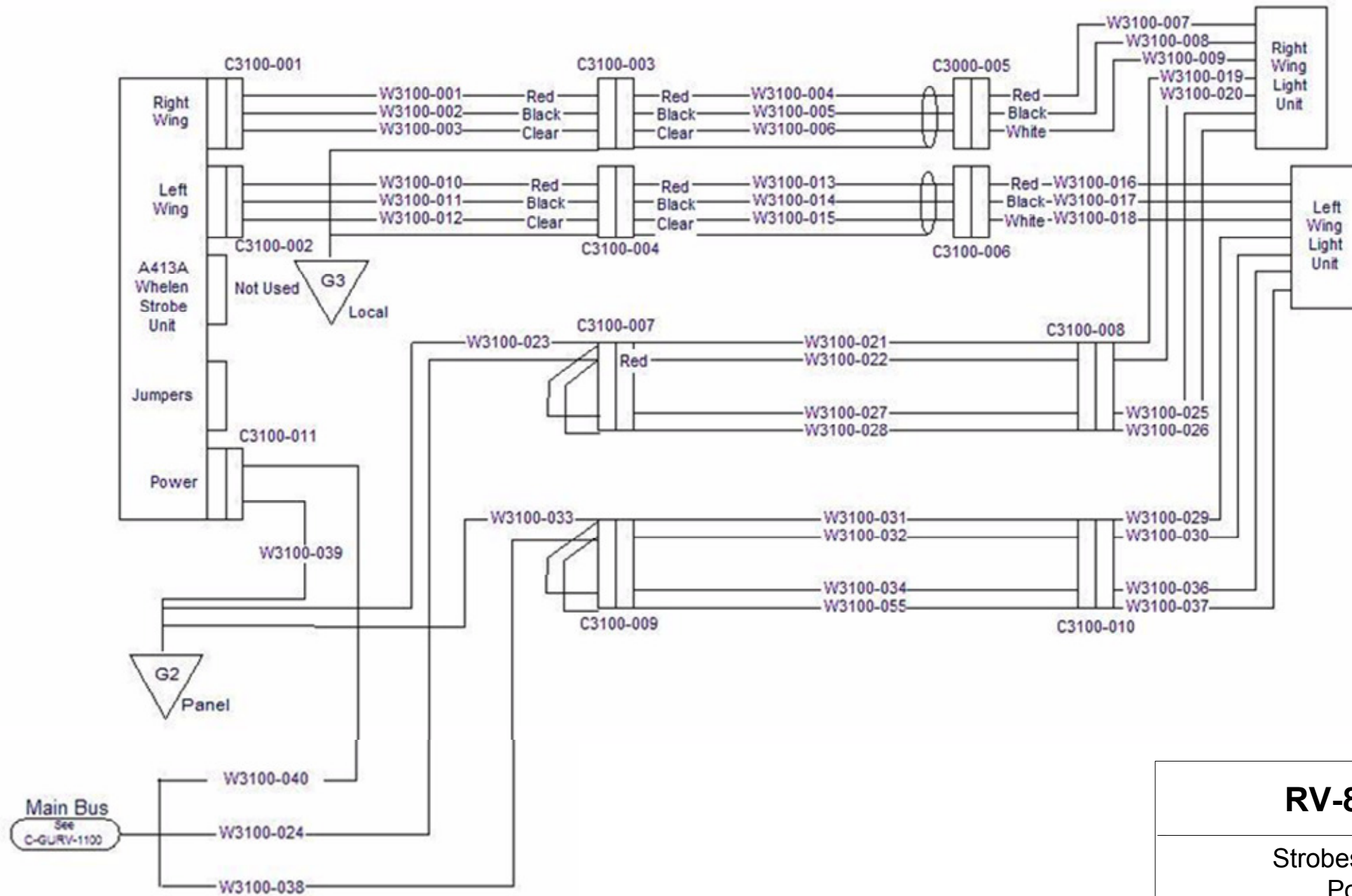

RV-8 C-GURV		
Strokes, Navigation and Position Lights		
Code	Dwg No. C-GURV- 3100	Rev 5
Drawn By M. Richardson	Date 27 Sept 2011	
Scale None	Page: 18 of 20	

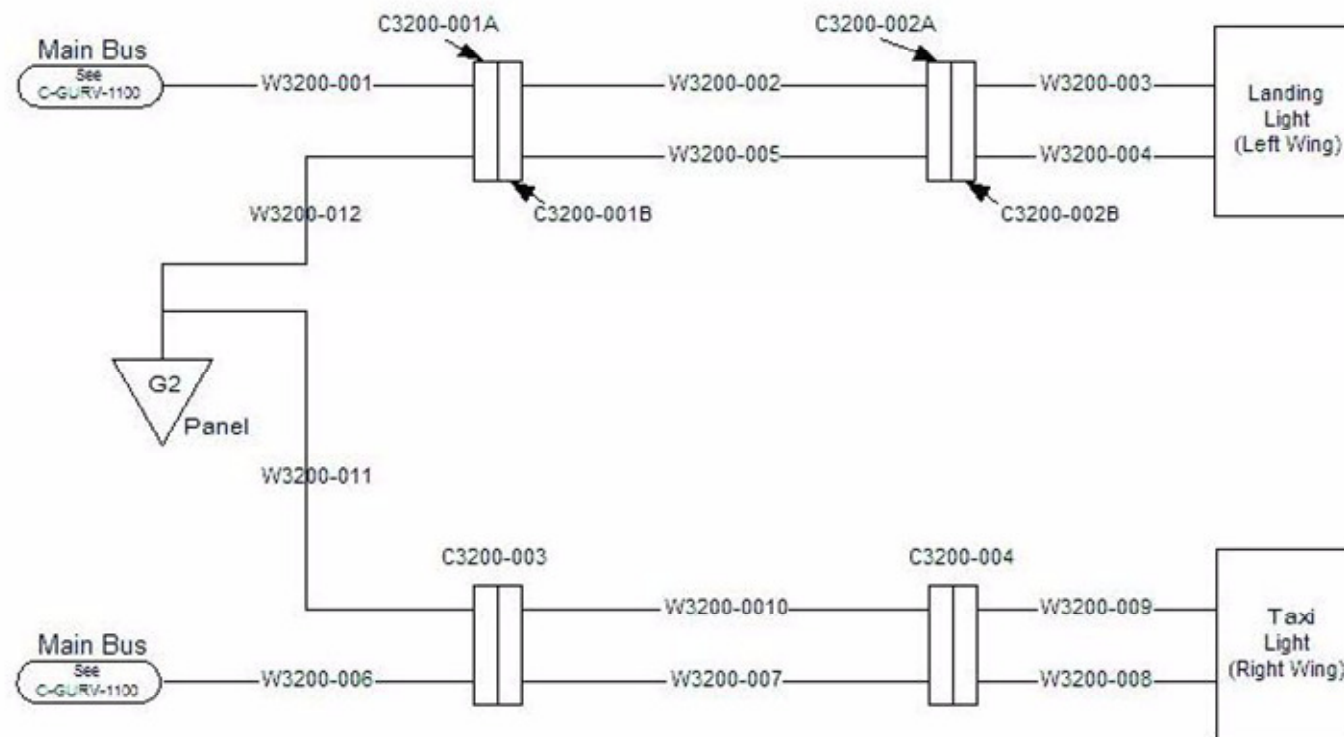

RV-8 C-GURV

Landing and Taxi Lights

Code	Dwg No.	Rev
	C-GURV- 3200	5
Drawn By	Date	
M. Richardson	27 Sept 2011	
Scale	Page: 19 of 20	
None		

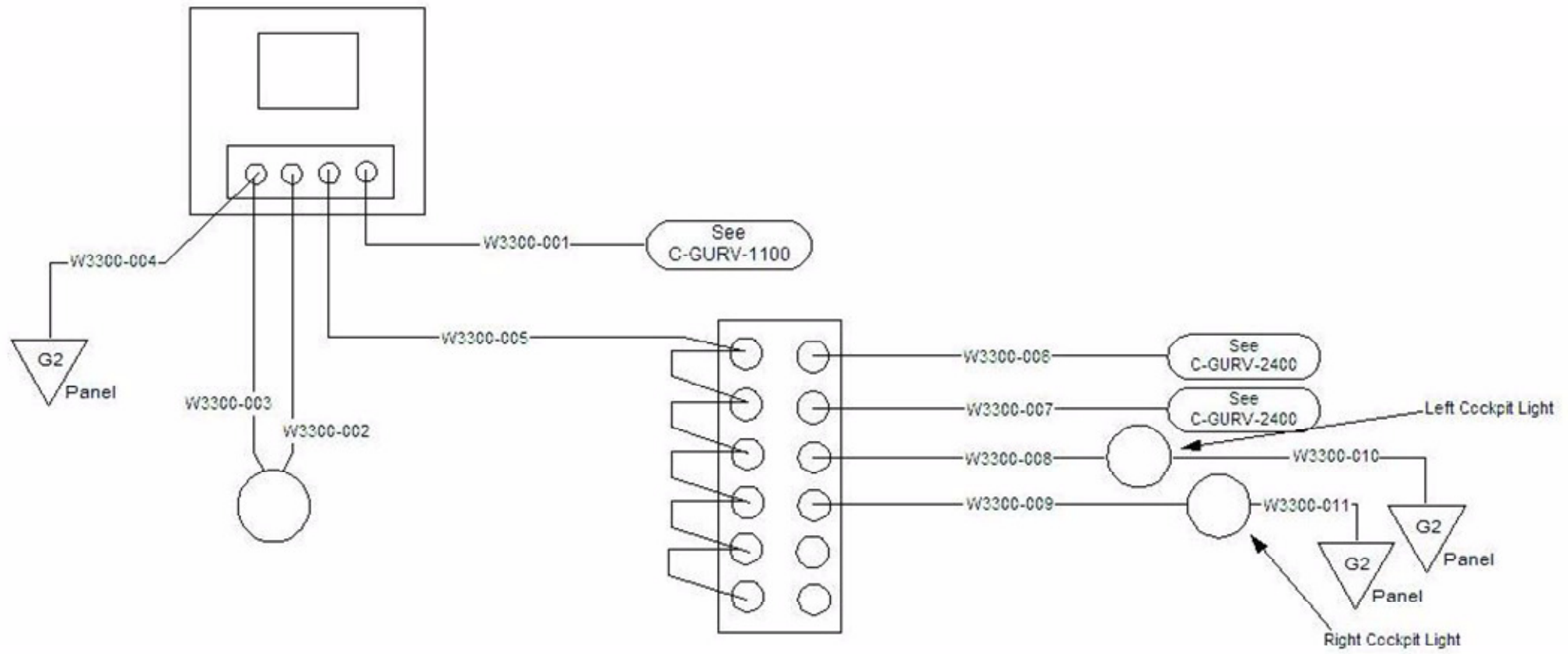

RV-8 C-GURV			
Panel Lights			
Code	Dwg No.	C-GURV- 3300	Rev 5
Drawn By	M. Richardson		Date 27 Sept 2011
Scale	None	Page: 20 of 20	